

CM43

DIESEL ENGINE GENERATOR SET

10 475 - 13 970 kWe

500 rpm

50 Hz



FEATURES

Designed for Reliable Operation

- Design includes intensive cooling of key components including exhaust valve seats, injector cooling integrated into lube oil system and high-efficiency turbocharger
- Capable of operation up to 700 cSt/50° C fuel quality according to CIMAC H55/K55

Minimized Mechanical Wear

- Modular design and state-of-the-art material ensure long life of components

Overall Economy

- Cost savings include high availability, long life, low fuel and oil consumption and low maintenance requirements

Highest Quality Engine Parts

- Semi-dry wear resistant liners with calibration inserts
- Pistons with forged steel crown and aluminum skirt
- Inlet/outlet valves with armored seats
- High-efficiency turbocharger

One-Piece Dry Engine Block

- High-strength nodular cast iron with under slung crankshaft and free from cooling water

Ease of Maintenance and Reliability

- Designed to provide efficient maintenance including easily removable cylinder heads, quick removable fluid connections and split connecting rods to allow piston removal without disturbing the big end bearing
- High reliability, modular design and integral construction reduce the number of components by 40% over conventional designs

ENGINE

- Engine type: 4-stroke cycle diesel engine
- Cylinder configuration: Vee - 12, 16
- Fuel type: LFO, CRO and HFO up to 700 cSt
- Bore: 430 mm (16.9 in)
- Stroke: 610 mm (24.0 in)
- Cylinder displacement: 88.6 L (5406 cu in)
- Cylinder output: 900 kW (1207 bhp)
- Mean piston speed: 10.2 m/s (33.4 ft/s)
- Mean effective pressure: 24.4 bar (354 psig)
- Aspiration: Turbocharged and after-cooled
- Compression ratio: 15.5:1
- Engine rating: 10 800–14 400 kW
- Generator set rating: 10 475–13 970 kWe

Total Power Solutions

- Caterpillar® can develop, finance, design, build, test, maintain and operate medium speed reciprocating engine power plants, plant assets and at the customer's option provide:
 - Power generation equipment
 - Engineered systems
 - Combined heat and power systems
 - Construction and installation services
 - Operation and maintenance services
 - Turnkey power plants
 - Contract power

Worldwide Product Support

- With nearly 200 Cat® dealers and 1,500 facilities worldwide serving in excess of 200 countries, you're never far from the Caterpillar support you need
- Customer Support Agreements offer back-to-back services from scheduled inspections, preventive maintenance and overhauls to full operations and maintenance

CM43

DIESEL ENGINE GENERATOR SET

NOMINAL PERFORMANCE

	ENGINE RATING		GENERATOR SET RATING		SPEED	FREQUENCY	HEAT RATE		SPECIFIC LUBE OIL CONSUMPTION	
	kWm	kWe	kVA	rpm			Hz	kJ/kWh	Btu/kWh	g/kWh
12CM43	10,800	10,475	13,094	500	50	7,572	7,176	0.6	0.0013	
16CM43	14,400	13,970	17,460	500	50	7,572	7,176	0.6	0.0013	

RATING DEFINITIONS AND CONDITIONS

Fuel type: Light fuel oil (LFO), crude oil (CRO) and heavy fuel oil (HFO) with fuel quality limit at 50° C according to CIMAC H55/K55.

Ratings: Based on ISO3046/1 standard reference conditions.

Power output: May require adjustment for values other than ISO3046/1 standard reference conditions.

Continuous output: Available for an unlimited time without varying load.

Generator efficiency: Efficiency of 97.0% based on 0.8 pf with medium voltage class generator; actual efficiency will depend on generator selection.

Fuel consumption: Based on ISO3046/1 standard reference conditions of 25° C (77° F) and 100 kPa (29.61 in Hg), excluding engine-driven pumps, with 5% tolerance and LCV = 42 700 kJ/kg (18,358 Btu/lb). Value based on measurement at the generator terminals.

Lube oil consumption: Tolerance on value of ±0.3 g/kWh (0.0007 lb/kWh). Lube oil consumption can only be demonstrated after 500 hours of operation.

GENERATOR SET DIMENSIONS

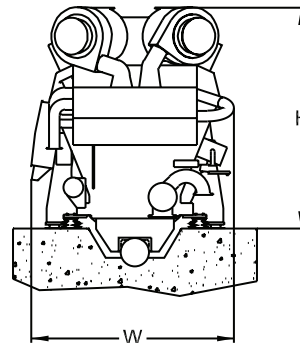
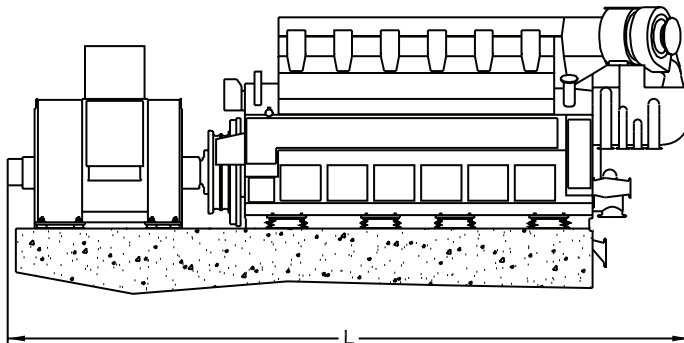

FOR MORE INFORMATION
 Email: cat-powerplants@cat.com
 Internet: <http://www.cat.com/powerplants>

	GENERATOR SET DIMENSIONS						APPROXIMATE WEIGHT (DRY)			
	HEIGHT (H)		WIDTH (W)		LENGTH (L)		ENGINE		GENERATOR	
	mm	in	mm	in	mm	in	kg	lb	kg	lb
12CM43	4,524	178	4,147	163	13,947	549	162,000	357,148	50,050	110,341
16CM43	4,524	178	4,147	163	15,891	626	215,000	473,990	66,500	146,607